

#17 Type AB 304SS Self-tapping Metal to Metal Fastener

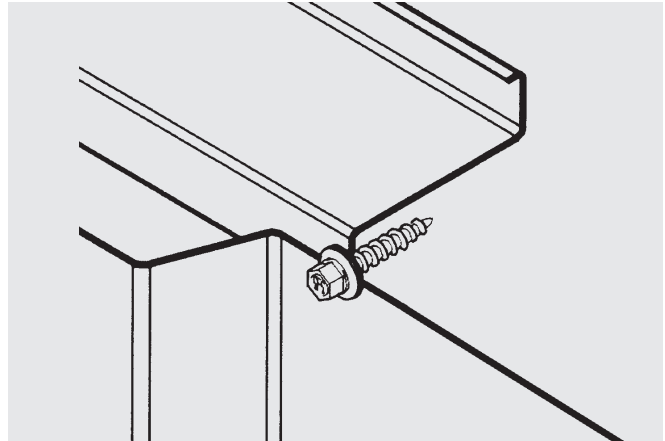

Features and Benefits

- Zinc plated 304 stainless steel for lubricity
- Available with no sealing washer or with stainless bond seal washer

Application

Metal panel to light and medium gauge metal application for use in highly corrosive environments

Product Selection

Material No.		Fastener Length		Thread Length*	Load Bearing Length		Description		Carton Wt. (lbs.)	Carton Qty.
No washer	W/washer	in	mm		in	mm	No washer	Washer suffix		
1297899	790721	3/4"	19	Full	0.39"	10	TAB-S3-#17x3/4-H3/8	SB19/32	38	2,500
1297908	790731	1"	25	Full	0.64"	16	TAB-S3-#17x1-H3/8	SB19/32	38	2,000
1297914	790740	1-1/2"	38	Full	1.14"	29	TAB-S3-#17x1-1/2-H3/8	SB19/32	36	1,500

Plain product bulk carton packed.

*Note – Thread length measured from tip of point to top of the threads.



#17 Type AB 304SS Self-tapping Metal to Metal Fastener

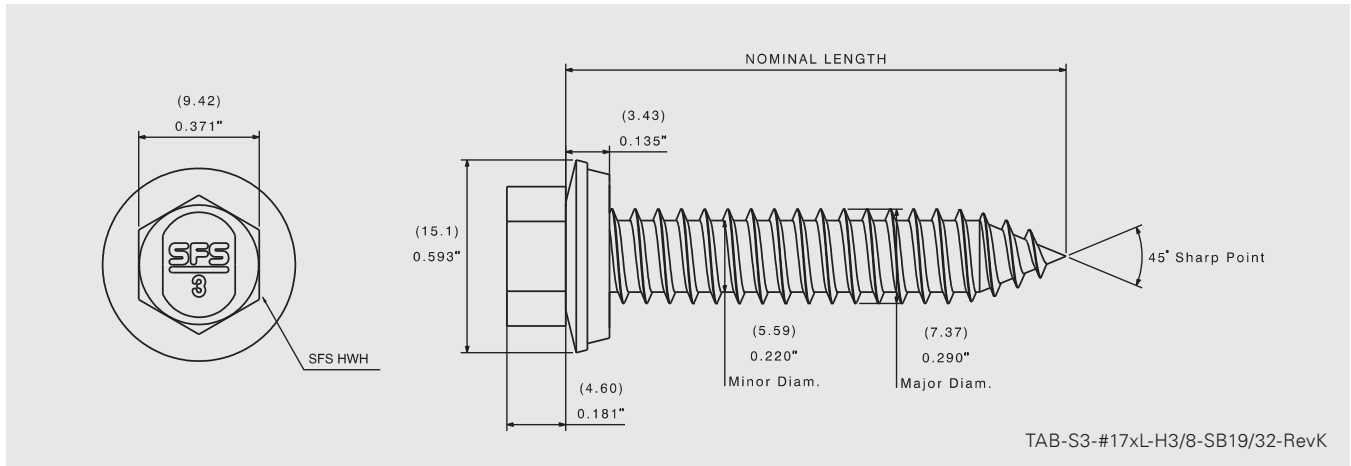

Product Specifications

Diameter:	#17 (7.37 mm)	Drill Point:	Type AB
Threads Per Inch:	14	Drill Capacity:	0.036"–0.060" (0.91 mm–1.52 mm)
Head Style:	3/8" dia. HH AF (9.42 mm)	Thread Major Dia:	0.290" (7.37 mm)
Washer:	19/32" stainless and EPDM bond seal (15.1 mm)	Thread Minor Dia:	0.220" (5.59 mm)

Performance Data^{1,2}

Material Strength

Tensile	5709 lbf / 25395 N
Shear	3906 lbf / 17375 N
Torsional	180 lbf-in / 20.34 N·m

Pull Out Strength Steel

14 Ga (1.9 mm)	1059 lbf / 4710 N
12 Ga (2.7 mm)	2518 lbf / 11200 N

Pull Over Strength Steel

26 Ga (0.5 mm):	562 lbf / 2499 N
24 Ga (0.6 mm):	1110 lbf / 4937 N

¹ SFS 5093.14, 5071.13

² PLK 15908

Installation and Application Considerations

Tools: 0–1000 rpm screw gun equipped with depth sensing nose piece.

Fastener length should provide for a minimum of 3/16" penetration of fully developed threads into metal substrate.

Use of impact guns or hammer drills is not recommended.