

#17 Type AB Self-tapping Metal to Metal Fastener

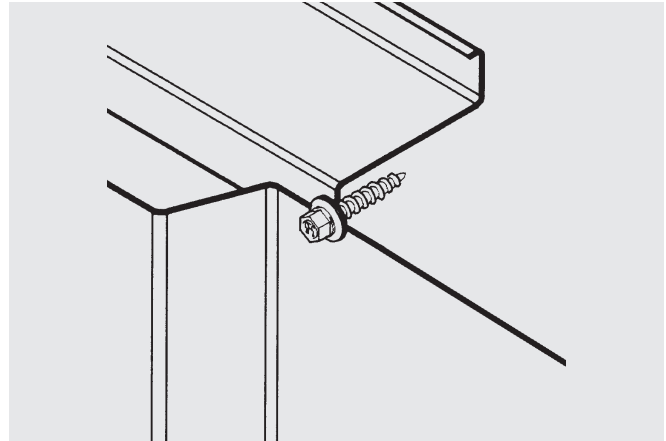

Features and Benefits

- Zinc plated carbon steel
- Available with no sealing washer or with bond seal washer

Application

Strip out repair of metal panel to light and medium gauge metal applications

Product Selection

Material No.	Fastener Length		Thread Length*	Load Bearing Length		Description	Carton Wt. (lbs.)	Carton Qty.
	(in)	(mm)		(in)	(mm)			
784798	3/4"	19	Full	0.39"	10	TAB-#17x3/4-H3/8-GB19/32	38	2,500
784832	1"	25	Full	0.64"	16	TAB-#17x1-H3/8-GB19/32	38	2,000
784938	1-1/2"	38	Full	1.14"	29	TAB-#17x1-1/2-H3/8-GB19/32	36	1,500

Plain product bagged 250 pieces, unless otherwise noted.

*Note - Thread length measured from tip of the point to top of the threads.



#17 Type AB Self-tapping Metal to Metal Fastener

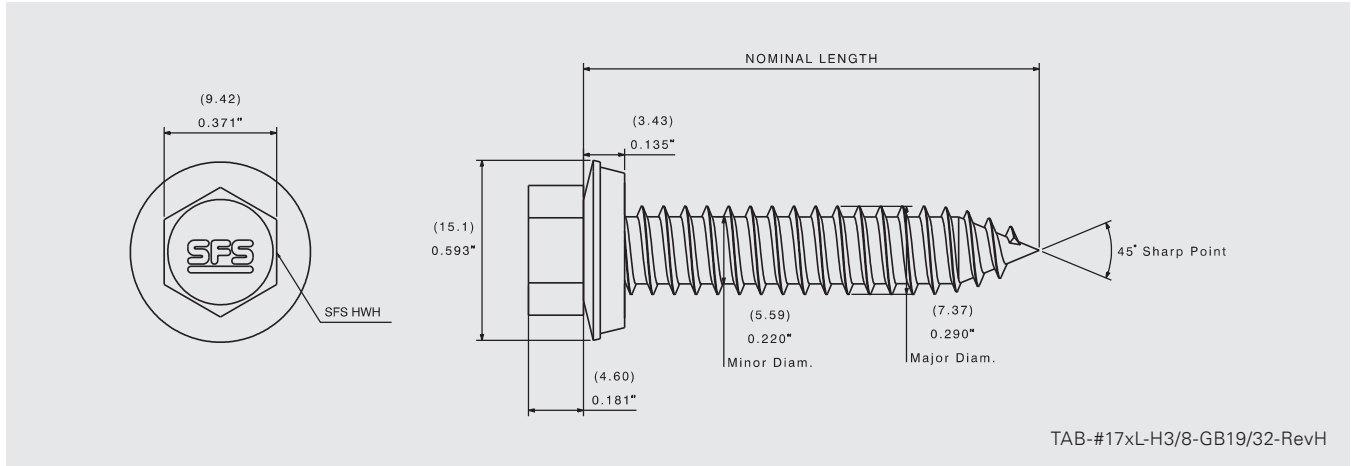

Product Specifications

Diameter: #17 (7.37 mm)
 Threads Per Inch: 14
 Head Style: 3/8" dia. HH AF (9.42mm)
 Washer: 19/32" galvanized and EPDM bond seal (15.1 mm)

Drill Point: Type AB
 Drill Capacity: 0.036"–0.060" (0.91 mm–1.52 mm)
 Thread Major Dia: 0.290" (7.37 mm)
 Thread Minor Dia: 0.220" (5.59 mm)

Performance Data^{1,2}

Material Strength

Tensile	5136 lbf / 22846 N
Shear	4830 lbf / 21485 N
Torsional	220 lbf·in / 24.86 N·m

Pull Out Strength Steel

14 Ga (1.9 mm)	986 lbf / 4386 N
12 Ga (2.7 mm)	1668 lbf / 7420 N

Pull Over Strength Steel

26 Ga (0.5 mm)	599 lbf / 2664 N
-----------------------	------------------

¹ Pull out values are tested/interpolated based on 50,000 psi hot rolled steel sheet material.

² SFS [4516.09, 4516.08]

Installation and Application Considerations

Tools: 0–1000 rpm screw gun equipped with depth sensing nose piece.

Fastener length should provide for a minimum of 3/16" penetration of fully developed threads into metal substrate.

Use of impact guns or hammer drills is not recommended.