

#12-14 MAC™ Impax SD3 Metal to Metal Fastener

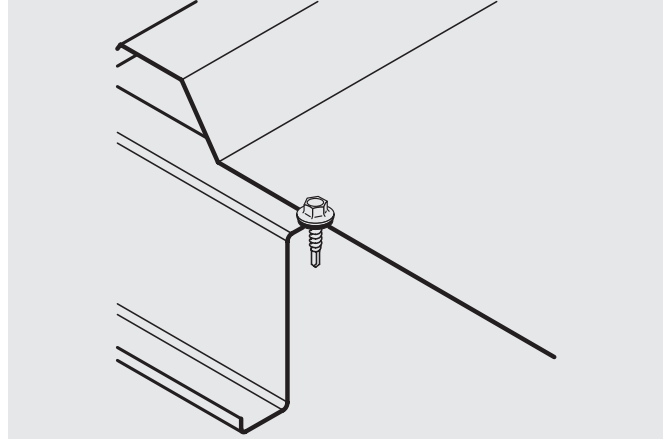

Features and Benefits

- 300 series stainless steel capped, integral cupped hex washer head configuration that can never red rust
- Assembled with EPDM washer
- Designed and engineered to have low driving and thread engagement torque and provide maximum clamp load
- Fasteners 1" and longer have special long pilot lengths to accommodate nested purlins
- Long life fastener limited warranty

Application

Metal panel to light and medium gauge metal application

Product Selection

Material No.	Fastener Length		Thread Length*	Load Bearing Length		Description	Carton Wt. (lbs.)	Carton Qty.
	(in)	(mm)		(in)	(mm)			
793796	1"	25	Full	0.35"	9	MSD3-#12x1-HW5/16-N	25	2,000
795388	1-1/4"	32	Full	0.60"	15	MSD3-#12x1-1/4-HW5/16-N	29	2,000
796239	1-1/2"	38	Full	0.85"	22	MSD3-#12x1-1/2-HW5/16-N	24	1,500
796653	2"	51	Full	1.35"	34	MSD3-#12x2-HW5/16-N	19	1,000

Plain product bagged 250 pieces, unless otherwise noted.

*Note – Thread length measured from end of pilot length to end of the threads.



#12-14 MAC™ Impax SD3 Metal to Metal Fastener

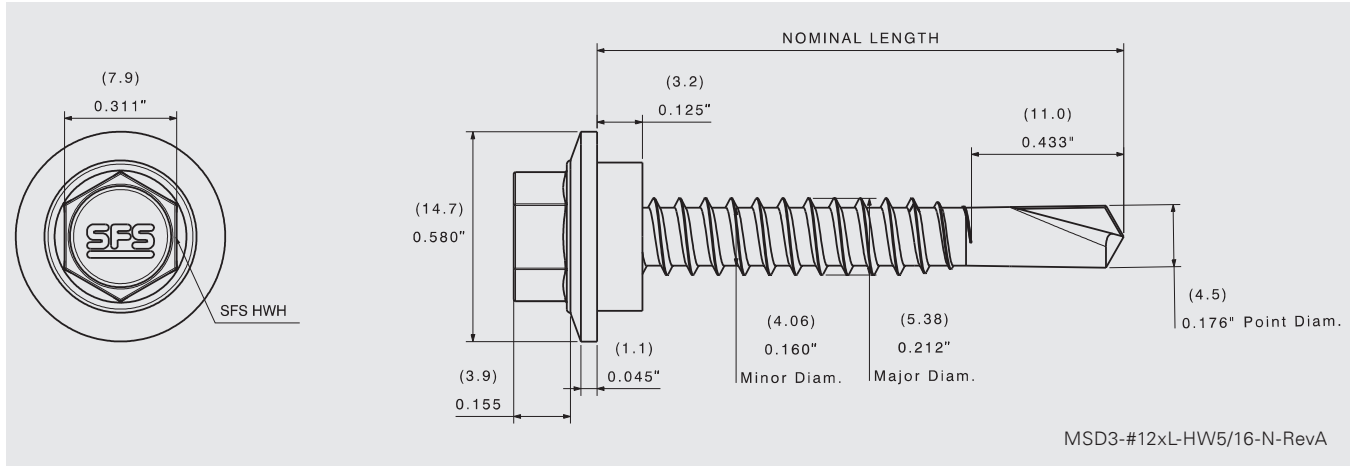

Product Specifications

Diameter: #12 (5.38 mm)
 Threads Per Inch: 14
 Head Style: 5/16" dia. Stainless Capped HWH AF
 (7.9 mm)
 Washer: EPDM sealing washer

Drill Point: SD3
 Drill Capacity: 0.035–0.210" (0.889 mm–5.334 mm)
 Thread Major Dia: 0.212" (5.38 mm)
 Thread Minor Dia: 0.160" (4.06 mm)

Performance Data^{1,2}

Material Strength

Tensile	2900 lbf / 12900 N
Shear	2050 lbf / 9119 N
Torsional	92 lbf-in / 10.39 N·m

Pull Out Strength Steel

	ICC protocol 45 ksi	SFS testing 56 ksi
16 Ga (1.5 mm)	516 lbf / 2295 N	665 lbf / 2958 N
14 Ga (1.9 mm)	782 lbf / 3478 N	901 lbf / 4008 N
12 Ga (2.7 mm)	1315 lbf / 5849 N	1524 lbf / 6779 N

Pull Over Strength Steel

26 Ga (0.5 mm)	692 lbf / 3078 N
24 Ga (0.6 mm)	1102 lbf / 4902 N
22 Ga (0.8 mm)	1298 lbf / 5774 N

¹ SFS [5083.14]

² STQA50573

Installation and Application Considerations

Tools: 0–2000 rpm screw gun equipped with depth sensing nose piece.

Fastener length should provide for a minimum of 3/16" penetration of fully developed threads into metal substrate.

Use of impact guns or hammer drills is not recommended.