

1/4-14 MAC™ Impax Lap Panel to Panel Fastener

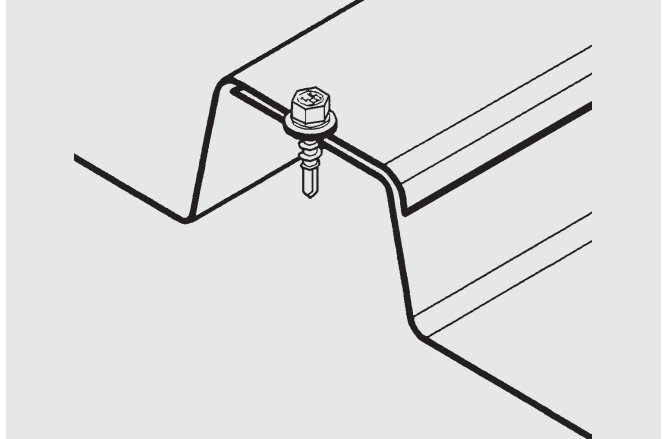

Features and Benefits

- 300 series stainless steel capped, integral cupped hex washer head configuration that can never red rust
- Self-drill point for fast installation
- Assembled with EPDM washer
- Long life fastener limited warranty

Application

Panel to panel side lap, end lap, and other stitch applications

Product Selection

Material No.	Fastener Length		Thread Length*	Description	Carton Wt. (lbs.)	Carton Qty.
	(in)	(mm)				
798360	7/8"	22	Full	MSDL-#14x7/8-HW5/16-N	24	2,000

Plain product bagged 250 pieces, unless otherwise noted.

*Note – Thread length measured from end of pilot length to end of the threads.



1/4-14 MAC™ Impax Lap Panel to Panel Fastener

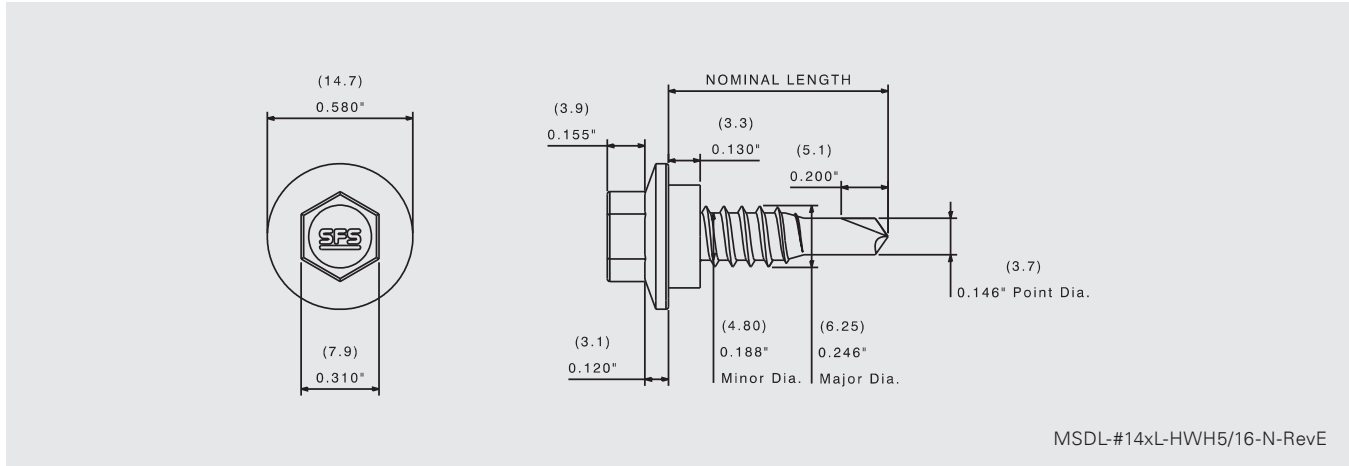

Product Specifications

Diameter:	1/4"	Drill Point:	SD1
Threads Per Inch:	14	Drill Capacity:	0.030–0.095" (0.762 mm–2.413 mm)
Head Style:	5/16" dia. cupped HWH AF (7.9 mm)	Thread Major Dia:	0.246" (6.25 mm)
Washer:	EPDM sealing washer	Thread Minor Dia:	0.188" (4.8 mm)

Performance Data^{1,2}

Material Strength

Tensile	3600 lbf / 16020 N
Shear	2700 lbf / 12015 N
Torsional	150 lbf-in / 17 N-m

Pull Out Strength Steel

26 Ga (0.5 mm)	204 lbf / 907 N
24 Ga (0.6 mm)	304 lbf / 1352 N
22 Ga (0.8 mm)	379 lbf / 1686 N

¹ SFS [5625.19, 3785.02]

² PLK 10403

Installation and Application Considerations

Tools: 0–2000 rpm screw gun equipped with depth sensing nose piece.

Composite thickness should not exceed 0.095" (2.4 mm).

Use of impact guns or hammer drills is not recommended.