



ETA-Danmark A/S
Göteborg Plads 1
DK-2150 Nordhavn
Tel. +45 72 24 59 00
Internet www.etadanmark.dk

Authorised and notified according
to Article 29 of the Regulation (EU)
No 305/2011 of the European
Parliament and of the Council of 9
March 2011

MEMBER OF EOTA



European Technical Assessment ETA-23/1026 of 2024/01/29

General Part

Technical Assessment Body issuing the ETA and designated according to Article 29 of the Regulation (EU) No 305/2011: ETA-Danmark A/S

Trade name of the
construction product:

SFS CX+CD screws

Product family to which the
above construction product
belongs:

Fastening screws for metal members and sheeting

Manufacturer:

SFS Group Schweiz AG
Rosenbergsaustrasse 10
CH-9435 Heerbrugg

Manufacturing plant:

SFS Production Plants

This European Technical
Assessment contains:

19 pages including 14 annexes which form an integral
part of the document

This European Technical
Assessment is issued in
accordance with Regulation
(EU) No 305/2011, on the
basis of:

EAD 330046-01-0602 – Fastening screws for metal
members and sheeting

This version replaces:

-

Translations of this European Technical Assessment in other languages shall fully correspond to the original issued document and should be identified as such.

Communication of this European Technical Assessment, including transmission by electronic means, shall be in full (excepted the confidential Annex(es) referred to above). However, partial reproduction may be made, with the written consent of the issuing Technical Assessment Body. Any partial reproduction has to be identified as such.

II SPECIFIC PART OF THE EUROPEAN TECHNICAL ASSESSMENT

1 Technical description of product

The products are fastening screws SFS CX + CD made of stainless steel. The fastening screws are normally completed with sealing washer consisting of a metal washer and EPDM seal. The fastening screws are made of austenitic stainless steel.

The fastening screws and the corresponding connections are subject to tension and/or shear forces.

screw	material	washer
CX-5,5x29	Stainless steel A2 – EN 3506	Ø16,0 mm
CX-6,0x25	Stainless steel A2 – EN 3506	Ø16,0 mm
CD-6,0x25	Stainless steel A2 – EN 3506	Ø16,0 mm

Table 1. Fastening screws covered by this ETA

The components identified in Table 2 have the geometrical characteristics defined in the Annexes and are factory produced by different manufacturing plants.

2 Specification of the intended use(s) in accordance with the applicable European Assessment Document (hereinafter EAD)

The SFS fastening screws CX+CD are intended to be used for fastening metal members and sheeting to metal or timber supporting structures.

The sheeting can either be used as wall or roof cladding or as load bearing wall and roof element. The fastening screws can also be used for the fastening of any other thin gauge metal members.

The intended use comprises fastening screws for metal members and sheeting and connections for indoor and outdoor applications. Fastening screws which are intended to be used in external environments with \geq C2 corrosion according to the standard EN ISO 12944-2 are made of stainless steel. Furthermore the intended use comprises connections with predominantly static loads (e.g. wind loads, dead loads).

The fastening screws for metal members and sheeting are not intended for re-use.

The field of application of the screws is shown in Table 2. The corresponding sheet thicknesses are shown in the annexes.

The installation should be carried out according to the ETA holder's specifications, using the specific kit components, manufactured by suppliers of the ETA holder and carried out by appropriately qualified staff with supervision of the technical responsible of the site.

The verification and assessment methods on which this European Technical Assessment is based lead to the assumption of a working life of at least 25 years, that the conditions lay down for the installation, packaging, transport and storage as well as appropriate use, maintenance and repair are met.

The indications given on the working life cannot be interpreted as a guarantee given by the manufacturer but are to be regarded only as a means for choosing the right product in relation to the expected economically reasonable working life of the works.

screw	washer	Material of components		Annex
		comp I	comp II	
CX-5,5xL	ds \geq 16,0 mm	steel	steel	4
		steel	steel	5
CX-6,0xL	ds \geq 16,0 mm	aluminum	aluminum	6
		aluminum	steel	7
		aluminum pre-drilled	aluminum	8
		aluminum pre-drilled	steel	9
		steel	steel	10
CD-6,0xL	ds \geq 16,0 mm	aluminum	aluminum	11
		aluminum	steel	12
		aluminum pre-drilled	aluminum	13
		aluminum pre-drilled	steel	14
		steel	steel	14

The maximum drill-capacities were provided by the manufacturer

Table 2: Fastening screws included in this ETA.

3 Performance of the product and references to the methods used for its assessment.

Characteristic	Assessment of characteristic
3.1 Mechanical resistance and stability (BWR 1)	
Shear resistance of the connection	See information in annex 4-15
Tension resistance of the connection	See information in annex 4-15
Design resistance in case of combined tension and shear forces (interaction)	Calculated according to equation in annex 3 with the combined tension and shear forces from annex 4-15.
Check of deformation capacity in case of constraining forces due to temperature	No performance assessed
Durability	Not relevant. The fastening screws are made of stainless steel intended to be used in external environments with \geq C2 corrosion. Sealing Washer: No performance assessed
3.2 Safety in case of fire (BWR 2)	
Reaction to fire	The SFS fastening screws are classified as Euroclass A1 in accordance with EN 13501-1 and Commission Delegated Regulation 2016/364 on the basis of EC Decision 96/603/EC (as amended) without the need for further testing.

3.8 Methods of verification

The product is fully covered by EAD EAD 330046-01-0602.

3.9 General aspects related to the fitness for use of the product.

The European Technical Assessment is issued for the product based on agreed data/information, deposited with ETA-Danmark, which identifies the product that has been assessed and judged. Changes to the product or production process, which could result in this deposited data/information being incorrect, should be notified to

ETA-Danmark before the changes are introduced. ETA-Danmark will decide if such changes affect the ETA and consequently the validity of the CE marking based on the ETA and if so whether further assessment or alterations to the ETA, shall be necessary.

The SFS fasteners CX+CD for metal cladding panels are manufactured in accordance with the provisions of this European Technical Assessment using the manufacturing processes as identified in the inspection of the plant by the notified inspection body and laid down in the technical documentation.

4 Assessment and verification of constancy of performance (hereinafter AVCP) system applied, with reference to its legal base.

4.1 AVCP system

According to the decision 1998/214/ECEC of the European Commission, as amended by 2001/596/EC, the system(s) of assessment and verification of constancy of performance (see Annex III to Regulation (EU) No 305/2011) is 2+.

5 Technical details necessary for the implementation of the AVCP system, as provided for in the applicable EAD.

Technical details necessary for the implementation of the AVCP system are laid down in the control plan deposited at ETA-Danmark prior to CE marking.

Issued in Copenhagen on 2024-01-29 by

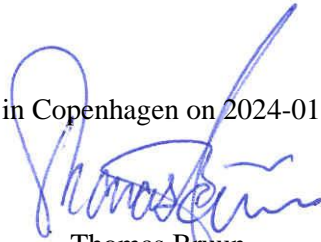

Thomas Bruun
Managing Director, ETA-Danmark

Examples of connections

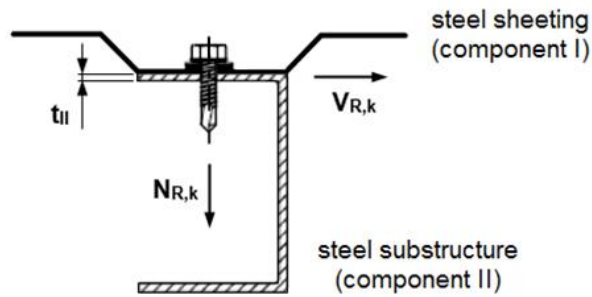

Description of the components

Component I Metal members or sheeting made of steel or aluminium

Component II Substructure made of steel or aluminium

Dimensions of the components

t_I Nominal thickness of metal member or sheeting

t_{II} Nominal thickness of steel or aluminium substructure

Assessed performance characteristics

$N_{R,k}$ Characteristic value of tension resistance of the connection

$V_{R,k}$ Characteristic value of shear resistance of the connection

$N_{R,II,k}$ Characteristic value of pull-out resistance of the substructure

Fastening screws for metal members and sheeting

Basics

Annex 1

Assessment of performance characteristics

The declared performance characteristics have been assessed according to EAD 330046-01-0602.

The characteristic value of tension resistance of a connection ($N_{R,k}$) results from the minimum of the tension resistance of the fastening screw (N_{screw}), the pull-through resistance of the metal member or sheeting ($N_{R,I,k}$) and the pull-out resistance of the substructure ($N_{R,II,k}$). The pull-through resistance includes a reduction factor 2/3 to take the influence of repeated wind loads into account.

$$N_{Rk} = \min\{N_{screw}; N_{R,I,k}; N_{R,II,k}\}$$

The characteristic value of shear resistance of a connection ($V_{R,k}$) results from the minimum of the shear resistance of the fastening screw (V_{screw}) and the shear resistance of the connection between metal member or sheeting and substructure ($V_{R,II,k}$).

$$V_{Rk} = \min\{V_{screw}; V_{R,II,k}\}$$

The characteristic values consider minimum thicknesses (t_{min}) of the declared nominal thicknesses ($t_{nom} = t_I, t_{II}$) according following table:

	t_{nom}	t_{min}	t_{nom}	t_{min}
	[mm]	[mm]	[mm]	[mm]
Steel components	0.40	0.33	1.00	0.91
	0.50	0.42	1.25	1.13
	0.63	0.55	1.50	1.38
	0.75	0.67	2.00	1.87
	0.88	0.79	2.50	2.36

	t_{nom}	t_{min}	t_{nom}	t_{min}	t_{nom}	t_{min}
	[mm]	[mm]	[mm]	[mm]	[mm]	[mm]
Aluminium components	0.50	0.44	0.90	0.82	2.00	1.85
	0.60	0.53	1.00	0.91	2.50	2.35
	0.70	0.63	1.20	1.10	3.00	2.85
	0.80	0.72	1.50	1.35	4.00	3.80

The characteristic values consider a minimum tensile strength of 360 N/mm² of the declared steel materials (S280GD, S235), a minimum tensile strength of 165 N/mm² and 215 N/mm² of the declared aluminium materials.

Characteristic values for component thicknesses (t_I, t_{II}) that are between two declared component thicknesses may be determined by linear interpolation.

The characteristic values may be applied for further steel materials according to EN 1993-1-1 (table 3.1) and EN 1993-1-3 (table 3.1) as long as the material properties corresponds to declared materials.

Fastening screws for metal members and sheeting	Annex 2
Basics	

Recommendation for design values

Provisions for the design of a connection are given in Eurocode 0 (EN 1990: Basis of structural design), Eurocode 3 (EN 1993: Design of steel structures) and Eurocode 9 (EN 1999: Design of aluminum structures).

The design value of tension and shear resistance of a connection ($N_{R,d}$ resp. $V_{R,d}$) shall be determined by taking into account a partial safety factor (γ_M). Recommended is $\gamma_M = 1.33$ unless otherwise stated in National Regulations or National Annexes of Eurocode 0, Eurocode 3 or Eurocode 9.

$$N_{R,d} = \frac{N_{R,k}}{\gamma_M} \qquad V_{R,d} = \frac{V_{R,k}}{\gamma_M}$$

Application specific conditions shall be taken into account:

- In case of combined tension and shear load of a connection, the condition according to EN 1993-1-3 (equation 8.2) resp. EN 1999-1-4 (equation 8.1) shall be fulfilled.
- In case of eccentric fastening of metal members or sheeting or asymmetrical steel or aluminium substructure, a reduction of tension resistance ($N_{R,k}$) according to EN 1090-4 (section B.5) and EN 1993-1-3 (section 8.3) resp. EN 1090-5 (section B.4) and EN 1999-1-4 (section 8.3) shall be applied.

Installation requirements

The installation has to be carried out according to the manufacturer's instructions.

Installation instructions given in corresponding European Standards shall be taken into account:

- Requirements on the installation of fastening screws are given in EN 1090-2 (section 8.8) and EN 1090-4 (section 8.1 and 8.2) resp. EN 1090-3 (section 8.5) and EN 1090-5 (section 8.1 and 8.2).
- Requirements on minimum distances between fastening screws and minimum distances to component edges and ends are given in EN 1090-4 (section 8.7) and EN 1993-1-3 (section 8.3), EN 1090-5 (section 8.6) and EN 1999-1-4 (section 8.1).
- Requirements on the minimum screw-in depth in steel substructures are given in EN 1090-4 (section 8.5).

Fastening screws for metal members and sheeting	Annex 3
Basics	

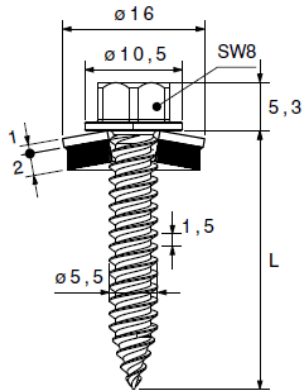

Materials:

Fastener: Stainless steel A2 or A4 - EN ISO 3506

Washer: Stainless steel A2 or A4 - EN ISO 3506 with EPDM-seal

Component I: Aluminum alloy - EN 573

Component II: S280GD to S350GD - EN 10346
S235 to S355 - EN 10025

Drilling-capacity: $\Sigma(t_{II}) \leq 0.90$ mm

For $t_i = 2.00$ mm component I can be pre-drilled with $\varnothing 6.5$ mm

For $t_i > 2.00$ mm component I must be pre-drilled with $\varnothing 6.5$ mm

Component I: Aluminum alloy with $R_m \geq 165$ N/mm ² Component II: S280GD to S350GD, S235						
t_i [mm]	t_{II} [mm]					
	0.40	0.50	0.55	0.63	0.75	0.88
V_{Rk} [kN] ≥ 2.00	0.81	0.81	0.81	0.81	0.81	0.81
N_{Rk} [kN] ≥ 2.00	0.51	0.76	0.86	1.04	1.28	1.28
$N_{R,II,k}$ [kN]	0.51	0.76	0.86	1.04	1.30	1.54

Self-drilling screw with sealing washer $\geq \varnothing 16$ mm

CX-S16-5,5xL

Annex 4

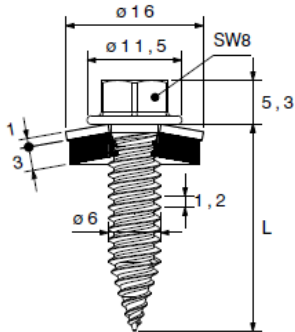

Materials:

Fastener: Stainless steel A2 or A4 - EN ISO 3506

Washer: Stainless steel A2 or A4 - EN ISO 3506 with EPDM-seal

Component I: S280GD to S350GD - EN 10346

Component II: S280GD to S350GD - EN 10346
S235 to S355 - EN 10025

Drilling-capacity: $\Sigma(t_i + t_{ii}) \leq 2.00$ mm

		t_{ii} [mm]								
		0.40	0.50	0.55	0.63	0.75	0.88	1.00	1.25	
V_{Rk} [kN]	0.40	1.02	1.02	1.02	1.02	1.02	1.02	1.02	1.02	
	0.50	1.02	2.03	2.03	2.03	2.03	2.03	2.03	2.03	
	0.55	1.02	2.03	2.14	2.14	2.14	2.14	2.14	2.14	
	0.63	1.02	2.03	2.14	2.31	2.31	2.31	2.31	-	
	t_i [mm]	0.75	1.02	2.03	2.14	2.31	2.57	2.57	2.57	-
	0.88	1.02	2.03	2.14	2.31	2.57	2.79	2.79	-	
	1.00	1.02	2.03	2.14	2.31	2.57	2.79	2.79	-	
	1.25	1.02	2.03	2.14	-	-	-	-	-	
N_{Rk} [kN]	0.40	0.58	0.94	1.07	1.27	1.29	1.29	1.29	1.29	
	0.50	0.58	0.94	1.07	1.27	1.57	1.79	1.79	1.79	
	0.55	0.58	0.94	1.07	1.27	1.57	1.84	1.95	1.95	
	0.63	0.58	0.94	1.07	1.27	1.57	1.84	2.20	-	
	t_i [mm]	0.75	0.58	0.94	1.07	1.27	1.57	1.84	2.20	-
	0.88	0.58	0.94	1.07	1.27	1.57	1.84	2.20	-	
	1.00	0.58	0.94	1.07	1.27	1.57	1.84	2.20	-	
	1.25	0.58	0.94	1.07	-	-	-	-	-	
$N_{R,II,k}$ [kN]		0.58	0.94	1.07	1.27	1.57	1.84	2.20	2.82	

Additional definitions

For component I and component II made of S320GD to S350GD the resistance value may be increased by 8.3%.

Self-drilling screw with sealing washer $\geq \text{Ø} 16$ mm

CX-S16-6,0xL

Annex 5

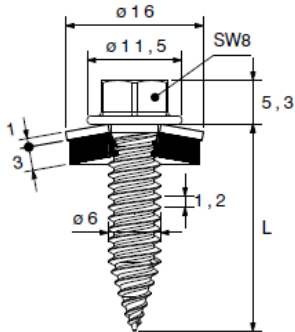

Materials:

Fastener: Stainless steel A2 or A4 - EN ISO 3506

Washer: Stainless steel A2 or A4 - EN ISO 3506 with EPDM-seal

Component I: Aluminum alloy - EN 573

Component II: Aluminum alloy - EN 573

Drilling-capacity: $\Sigma(t_i + t_{II}) \leq 3.00$ mm

Component I: Aluminum alloy with $R_m \geq 165$ N/mm ² Component II: Aluminum alloy with $R_m \geq 165$ N/mm ²							
t_i [mm]	t_{II} [mm]						
	0.50	0.60	0.70	0.80	1.00	1.20	1.50
0.50	0.60	0.60	0.60	0.60	0.60	0.60	0.60
0.60	0.60	0.79	0.79	0.79	0.79	0.79	0.79
0.70	0.60	0.79	1.11	1.11	1.11	1.11	1.11
0.80	0.60	0.79	1.11	1.43	1.43	1.43	1.43
1.00	0.60	0.79	1.11	1.43	1.61	1.61	1.61
1.20	0.60	0.79	1.11	1.43	1.61	1.95	1.95
1.50	0.60	0.79	1.11	1.43	1.61	1.95	2.46
$N_{R,II,k}$ [kN]	0.36	0.47	0.58	0.69	0.97	1.20	1.54

Component I: Aluminum alloy with $R_m \geq 215$ N/mm ² Component II: Aluminum alloy with $R_m \geq 215$ N/mm ²							
t_i [mm]	t_{II} [mm]						
	0.50	0.60	0.70	0.80	1.00	1.20	1.50
0.50	0.78	0.78	0.78	0.78	0.78	0.78	0.78
0.60	0.78	1.02	1.02	1.02	1.02	1.02	1.02
0.70	0.78	1.02	1.45	1.45	1.45	1.45	1.45
0.80	0.78	1.02	1.45	1.87	1.87	1.87	1.87
1.00	0.78	1.02	1.45	1.87	2.10	2.10	2.10
1.20	0.78	1.02	1.45	1.87	2.10	2.54	2.54
1.50	0.78	1.02	1.45	1.87	2.10	2.54	3.21
$N_{R,II,k}$ [kN]	0.47	0.61	0.76	0.91	1.27	1.56	2.00

Additional definitions

The resistance value $N_{R,k}$ can be determined as follows: $N_{R,k} = \min \{ N_{R,I,k} \mid N_{R,II,k} \}$. $N_{R,I,k}$ has to be calculated according to EN 1999-1-4:2007, equation (8.13).

Self-drilling screw with sealing washer $\geq \text{Ø} 16$ mm	Annex 6
CX-S16-6,0xL	

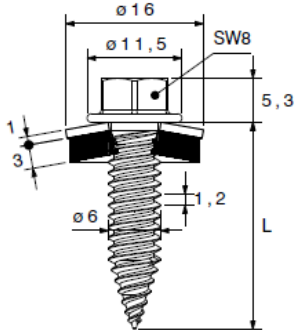

Materials:

Fastener: Stainless steel A2 or A4 - EN ISO 3506

Washer: Stainless steel A2 or A4 - EN ISO 3506 with EPDM-seal

Component I: Aluminum alloy - EN 573

Component II: S280GD to S350GD - EN 10346
S235 to S355 - EN 10025

Drilling-capacity: $\Sigma(t_i + t_{II}) \leq 3.00$ mm

Component I: Aluminum alloy with $R_m \geq 165$ N/mm²
Component II: S280GD to S350GD, S235

t_i [mm]	t_{II} [mm]								
	0.40	0.50	0.55	0.63	0.75	0.88	1.00	1.25	
$V_{R,k}$ [kN]	0.50	0.60	0.60	0.60	0.60	0.60	0.60	0.60	0.60
	0.60	0.79	0.79	0.79	0.79	0.79	0.79	0.79	0.79
	0.70	1.02	1.11	1.11	1.11	1.11	1.11	1.11	1.11
	0.80	1.02	1.43	1.43	1.43	1.43	1.43	1.43	1.43
	1.00	1.02	1.61	1.61	1.61	1.61	1.61	1.61	1.61
	1.20	1.02	1.95	1.95	1.95	1.95	1.95	1.95	1.95
	1.50	1.02	2.03	2.14	2.31	2.46	2.46	2.46	2.46
	2.00	1.02	2.03	2.14	2.31	2.57	2.79	2.79	-
$N_{R,II,k}$ [kN]	0.58	0.94	1.07	1.27	1.57	1.84	2.20	2.82	

Component I: Aluminum alloy with $R_m \geq 215$ N/mm²
Component II: S280GD to S350GD, S235

t_i [mm]	t_{II} [mm]								
	0.40	0.50	0.55	0.63	0.75	0.88	1.00	1.25	
$V_{R,k}$ [kN]	0.50	0.78	0.78	0.78	0.78	0.78	0.78	0.78	0.78
	0.60	1.02	1.02	1.02	1.02	1.02	1.02	1.02	1.02
	0.70	1.02	1.45	1.45	1.45	1.45	1.45	1.45	1.45
	0.80	1.02	1.87	1.87	1.87	1.87	1.87	1.87	1.87
	1.00	1.02	2.03	2.10	2.10	2.10	2.10	2.10	2.10
	1.20	1.02	2.03	2.14	2.31	2.54	2.54	2.54	2.54
	1.50	1.02	2.03	2.14	2.31	2.57	2.79	2.79	2.79
	2.00	1.02	2.03	2.14	2.31	2.57	2.79	2.79	-
$N_{R,II,k}$ [kN]	0.58	0.94	1.07	1.27	1.57	1.84	2.20	2.82	

Additional definitions

The resistance value $N_{R,k}$ can be determined as follows: $N_{R,k} = \min \{ N_{R,I,k} | N_{R,II,k} \}$. $N_{R,I,k}$ has to be calculated according to EN 1999-1-4:2007, equation (8.13).

Self-drilling screw with sealing washer $\geq \varnothing 16$ mm

CX-S16-6,0xL

Annex 7

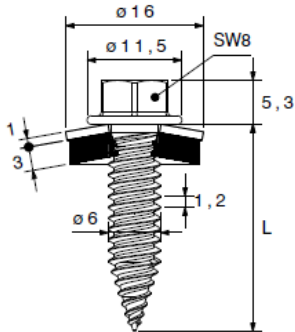

Materials:

Fastener: Stainless steel A2 or A4 - EN ISO 3506

Washer: Stainless steel A2 or A4 - EN ISO 3506 with EPDM-seal

Component I: Aluminum alloy - EN 573 – Pre-drilled

Component II: Aluminum alloy - EN 573

Drilling-capacity: $\Sigma(t_{II}) \leq 2.00$ mm

Component I: Aluminum alloy with $R_m \geq 165$ N/mm ² (pre-drilled \varnothing 6.5 mm) Component II: Aluminum alloy with $R_m \geq 165$ N/mm ²								
t_I [mm]	t_{II} [mm]							
	0.50	0.60	0.70	0.80	1.00	1.20	1.50	2.00
$V_{R,k}$ [kN] ≥ 2.00	0.43	0.62	0.82	1.01	1.31	1.61	2.07	2.07
$N_{R,k}$ [kN] ≥ 2.00	0.36	0.47	0.58	0.69	0.97	1.20	1.54	1.54
$N_{R,II,k}$ [kN]	0.36	0.47	0.58	0.69	0.97	1.20	1.54	1.54

Component I: Aluminum alloy with $R_m \geq 215$ N/mm ² (pre-drilled \varnothing 6.5 mm) Component II: Aluminum alloy with $R_m \geq 215$ N/mm ²								
t_I [mm]	t_{II} [mm]							
	0.50	0.60	0.70	0.80	1.00	1.20	1.50	2.00
$V_{R,k}$ [kN] ≥ 2.00	0.56	0.81	1.06	1.32	1.71	2.10	2.70	2.70
$N_{R,k}$ [kN] ≥ 2.00	0.47	0.61	0.76	0.91	1.27	1.56	2.00	2.00
$N_{R,II,k}$ [kN]	0.47	0.61	0.76	0.91	1.27	1.56	2.00	2.00

Self-drilling screw with sealing washer $\geq \varnothing$ 16 mm

CX-S16-6,0xL

Annex 8

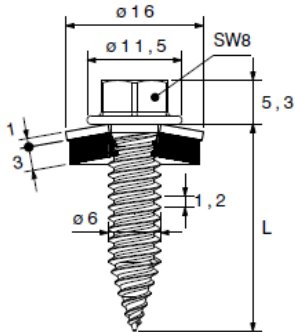

Materials:

Fastener: Stainless steel A2 or A4 - EN ISO 3506

Washer: Stainless steel A2 or A4 - EN ISO 3506 with EPDM-seal

Component I: Aluminum alloy - EN 573 – Pre-drilled

Component II: S280GD to S350GD - EN 10346
S235 to S355 - EN 10025

Drilling-capacity: $\Sigma(t_{II}) \leq 2.00$ mm

Component I: Aluminum alloy with $R_m \geq 165$ N/mm ² (pre-drilled \varnothing 6.5 mm) Component II: S280GD to S350GD, S235									
t_I [mm]	t_{II} [mm]								
	0.40	0.50	0.55	0.63	0.75	0.88	1.00	1.25	1.50
$V_{R,k} \geq 2.00$ [kN]	0.83	1.41	1.57	1.82	2.20	2.36	1.84	2.36	3.42
$N_{R,k} \geq 2.00$ [kN]	0.58	0.94	1.07	1.27	1.57	1.84	2.20	2.43	2.43
$N_{R,II,k}$ [kN]	0.58	0.94	1.07	1.27	1.57	1.84	2.20	2.82	3.49

Component I: Aluminum alloy with $R_m \geq 215$ N/mm ² (pre-drilled \varnothing 6.5 mm) Component II: S280GD to S350GD, S235									
t_I [mm]	t_{II} [mm]								
	0.40	0.50	0.55	0.63	0.75	0.88	1.00	1.25	1.50
$V_{R,k} \geq 2.00$ [kN]	0.83	1.41	1.58	1.86	2.27	2.54	2.40	2.68	4.11
$N_{R,k} \geq 2.00$ [kN]	0.58	0.94	1.07	1.27	1.57	1.84	2.20	2.82	3.16
$N_{R,II,k}$ [kN]	0.58	0.94	1.07	1.27	1.57	1.84	2.20	2.82	3.49

Self-drilling screw with sealing washer $\geq \varnothing$ 16 mm

CX-S16-6,0xL

Annex 9

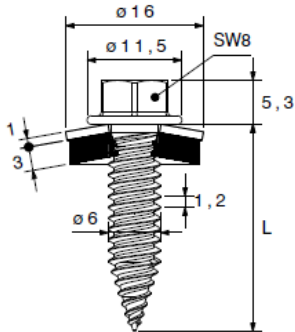

Materials:

Fastener: Stainless steel A2 or A4 - EN ISO 3506

Washer: Stainless steel A2 or A4 - EN ISO 3506 with EPDM-seal

Component I: S280GD to S350GD - EN 10346

Component II: S280GD to S350GD - EN 10346
S235 to S355 - EN 10025

Drilling-capacity: $\Sigma(t_i + t_{II}) \leq 1.80 \text{ mm}$

		$t_{II} \text{ [mm]}$					
		0.40	0.50	0.55	0.63	0.75	0.88
$V_{Rk} \text{ [kN]}$	0.40	0.59	0.59	0.59	0.59	0.59	0.59
	0.50	0.59	1.52	1.52	1.52	1.52	1.52
	0.55	0.59	1.52	1.52	1.52	1.52	1.52
	$t_i \text{ [mm]}$	0.63	0.59	1.52	1.52	1.52	1.52
	0.75	0.59	1.52	1.52	1.52	1.52	1.52
	0.88	0.59	1.52	1.52	1.52	1.52	1.52
$N_{Rk} \text{ [kN]}$	0.40	0.56	0.91	0.99	0.99	0.99	0.99
	0.50	0.56	0.91	1.02	1.20	1.30	1.30
	0.55	0.56	0.91	1.02	1.20	1.47	1.50
	$t_i \text{ [mm]}$	0.63	0.56	0.91	1.02	1.20	1.47
	0.75	0.56	0.91	1.02	1.20	1.47	1.79
	0.88	0.56	0.91	1.02	1.20	1.47	1.79
$N_{R,II,k} \text{ [kN]}$		0.56	0.91	1.02	1.20	1.47	1.79

Additional definitions

For component I and component II made of S320GD to S350GD the resistance value may be increased by 8.3%.

Self-drilling screw with sealing washer $\geq \text{Ø } 16 \text{ mm}$

CD-S16-6,0xL

Annex 10

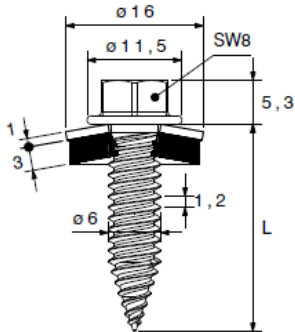

Materials:

Fastener: Stainless steel A2 or A4 - EN ISO 3506

Washer: Stainless steel A2 or A4 - EN ISO 3506 with EPDM-seal

Component I: Aluminum alloy - EN 573

Component II: Aluminum alloy - EN 573

Drilling-capacity: $\Sigma(t_i + t_{ii}) \leq 3.00$ mm

Component I: Aluminum alloy with $R_m \geq 165$ N/mm ² Component II: Aluminum alloy with $R_m \geq 165$ N/mm ²							
t_i [mm]	t_{ii} [mm]						
	0.50	0.60	0.70	0.80	1.00	1.20	1.50
0.50	0.59	0.59	0.59	0.59	0.59	0.59	0.59
0.60	0.59	0.76	0.76	0.76	0.76	0.76	0.76
0.70	0.59	0.76	1.02	1.02	1.02	1.02	1.02
0.80	0.59	0.76	1.02	1.27	1.27	1.27	1.27
1.00	0.59	0.76	1.02	1.27	1.78	1.78	1.78
1.20	0.59	0.76	1.02	1.27	1.78	2.01	2.01
1.50	0.59	0.76	1.02	1.27	1.78	2.01	2.36
$N_{R,II,k}$ [kN]	0.35	0.49	0.63	0.77	0.99	1.24	1.62

Component I: Aluminum alloy with $R_m \geq 215$ N/mm ² Component II: Aluminum alloy with $R_m \geq 215$ N/mm ²							
t_i [mm]	t_{ii} [mm]						
	0.50	0.60	0.70	0.80	1.00	1.20	1.50
0.50	0.76	0.76	0.76	0.76	0.76	0.76	0.76
0.60	0.76	0.99	0.99	0.99	0.99	0.99	0.99
0.70	0.76	0.99	1.32	1.32	1.32	1.32	1.32
0.80	0.76	0.99	1.32	1.66	1.66	1.66	1.66
1.00	0.76	0.99	1.32	1.66	2.32	2.32	2.32
1.20	0.76	0.99	1.32	1.66	2.32	2.63	2.63
1.50	0.76	0.99	1.32	1.66	2.32	2.63	3.08
$N_{R,II,k}$ [kN]	0.46	0.64	0.82	1.00	1.29	1.61	2.11

Additional definitions

The resistance value $N_{R,k}$ can be determined as follows: $N_{R,k} = \min \{ N_{R,I,k} | N_{R,II,k} \}$. $N_{R,I,k}$ has to be calculated according to EN 1999-1-4:2007, equation (8.13).

Self-drilling screw with sealing washer $\geq \text{Ø } 16$ mm	Annex 11
CD-S16-6,0xL	

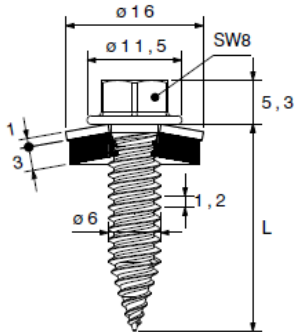

Materials:

Fastener: Stainless steel A2 or A4 - EN ISO 3506

Washer: Stainless steel A2 or A4 - EN ISO 3506 with EPDM-seal

Component I: Aluminum alloy - EN 573

Component II: S280GD to S350GD - EN 10346
S235 to S355 - EN 10025

Drilling-capacity: $\Sigma(t_i + t_{ii}) \leq 2.40$ mm

Component I: Aluminum alloy with $R_m \geq 165$ N/mm ² Component II: S280GD to S350GD, S235						
t_i [mm]	t_{ii} [mm]					
	0.40	0.50	0.55	0.63	0.75	0.88
0.50	0.59	0.59	0.59	0.59	0.59	0.59
0.60	0.59	0.76	0.76	0.76	0.76	0.76
0.70	0.59	1.02	1.02	1.02	1.02	1.02
0.80	0.59	1.27	1.27	1.27	1.27	1.27
1.00	0.59	1.52	1.52	1.52	1.52	1.52
1.20	0.59	1.52	1.52	1.52	1.52	1.52
1.50	0.59	1.52	1.52	1.52	1.52	1.52
$N_{R,II,k}$ [kN]	0.56	0.91	1.02	1.20	1.47	1.79

Component I: Aluminum alloy with $R_m \geq 215$ N/mm ² Component II: S280GD to S350GD, S235						
t_i [mm]	t_{ii} [mm]					
	0.40	0.50	0.55	0.63	0.75	0.88
0.50	0.59	0.76	0.76	0.76	0.76	0.76
0.60	0.59	0.99	0.99	0.99	0.99	0.99
0.70	0.59	1.32	1.32	1.32	1.32	1.32
0.80	0.59	1.52	1.52	1.52	1.52	1.52
1.00	0.59	1.52	1.52	1.52	1.52	1.52
1.20	0.59	1.52	1.52	1.52	1.52	1.52
1.50	0.59	1.52	1.52	1.52	1.52	1.52
$N_{R,II,k}$ [kN]	0.56	0.91	1.02	1.20	1.47	1.79

Additional definitions

The resistance value $N_{R,k}$ can be determined as follows: $N_{R,k} = \min \{ N_{R,I,k} | N_{R,II,k} \}$. $N_{R,I,k}$ has to be calculated according to EN 1999-1-4:2007, equation (8.13).

Self-drilling screw with sealing washer $\geq \text{Ø } 16$ mm	Annex 12
CD-S16-6,0xL	

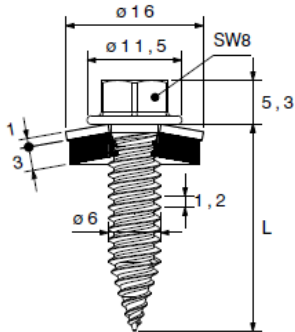

Materials:

Fastener: Stainless steel A2 or A4 - EN ISO 3506

Washer: Stainless steel A2 or A4 - EN ISO 3506 with EPDM-seal

Component I: Aluminum alloy - EN 573 – Pre-drilled

Component II: Aluminum alloy - EN 573

Drilling-capacity: $\Sigma(t_{II}) \leq 2.00$ mm

Component I: Aluminum alloy with $R_m \geq 165$ N/mm ² (pre-drilled \varnothing 6.5 mm) Component II: Aluminum alloy with $R_m \geq 165$ N/mm ²								
t_I [mm]	t_{II} [mm]							
	0.50	0.60	0.70	0.80	1.00	1.20	1.50	2.00
$V_{R,k}$ [kN] ≥ 2.00	0.45	0.66	0.88	1.10	1.32	1.71	2.29	2.29
$N_{R,k}$ [kN] ≥ 2.00	0.35	0.49	0.63	0.77	0.99	1.24	1.62	1.62
$N_{R,II,k}$ [kN]	0.35	0.49	0.63	0.77	0.99	1.24	1.62	1.62

Component I: Aluminum alloy with $R_m \geq 215$ N/mm ² (pre-drilled \varnothing 6.5 mm) Component II: Aluminum alloy with $R_m \geq 215$ N/mm ²								
t_I [mm]	t_{II} [mm]							
	0.50	0.60	0.70	0.80	1.00	1.20	1.50	2.00
$V_{R,k}$ [kN] ≥ 2.00	0.58	0.87	1.15	1.43	1.72	2.22	2.98	2.98
$N_{R,k}$ [kN] ≥ 2.00	0.46	0.64	0.82	1.00	1.29	1.61	2.11	2.11
$N_{R,II,k}$ [kN]	0.46	0.64	0.82	1.00	1.29	1.61	2.11	2.11

Self-drilling screw with sealing washer $\geq \varnothing$ 16 mm	Annex 13
CD-S16-6,0xL	

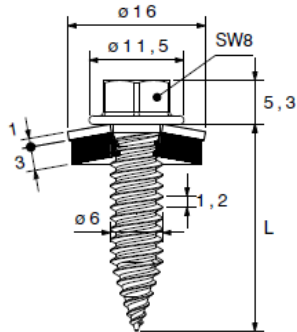

Materials:

Fastener: Stainless steel A2 or A4 - EN ISO 3506

Washer: Stainless steel A2 or A4 - EN ISO 3506 with EPDM-seal

Component I: Aluminum alloy - EN 573 – Pre-drilled

Component II: S280GD to S350GD - EN 10346
S235 to S355 - EN 10025

Drilling-capacity: $\Sigma(t_{II}) \leq 0.88$ mm

Component I: Aluminum alloy with $R_m \geq 165$ N/mm ² (pre-drilled \varnothing 6.5 mm) Component II: S280GD to S350GD, S235						
t_I [mm]	t_{II} [mm]					
	0.40	0.50	0.55	0.63	0.75	0.88
$V_{R,k}$ [kN] ≥ 2.00	0.84	1.40	1.56	1.81	2.19	2.26
$N_{R,k}$ [kN] ≥ 2.00	0.56	0.91	1.02	1.20	1.47	1.79
$N_{R,II,k}$ [kN]	0.56	0.91	1.02	1.20	1.47	1.79

Component I: Aluminum alloy with $R_m \geq 215$ N/mm ² (pre-drilled \varnothing 6.5 mm) Component II: S280GD to S350GD, S235						
t_I [mm]	t_{II} [mm]					
	0.40	0.50	0.55	0.63	0.75	0.88
$V_{R,k}$ [kN] ≥ 2.00	0.84	1.40	1.57	1.85	2.27	2.43
$N_{R,k}$ [kN] ≥ 2.00	0.56	0.91	1.02	1.20	1.47	1.79
$N_{R,II,k}$ [kN]	0.56	0.91	1.02	1.20	1.47	1.79

Self-drilling screw with sealing washer $\geq \varnothing$ 16 mm

CD-S16-6,0xL

Annex 14