

SXP2-HT-SC19-5,5

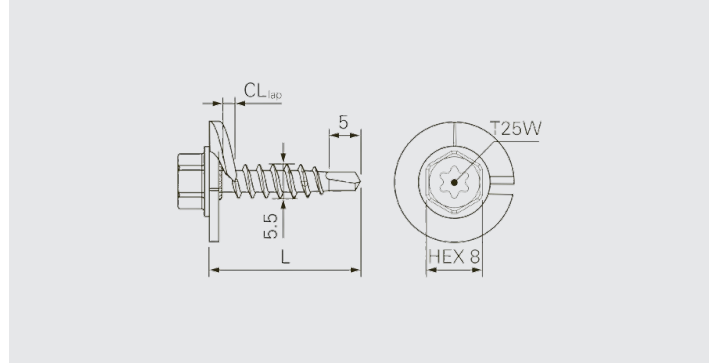

Application

Fastening of single ply insulated roof panel overlaps

Component 1 (t₁)

Single-ply panel

Component 2 (t_{II})

Steel 0.4-1.0

Max

2.0

Fastener material

Austenitic stainless steel A2, case hardened drill point
Cutting disc: Austenitic stainless steel A2

Approvals



Features and Benefits

- Self-drilling fastener suitable for both the fixing of single ply insulated roof panels into light gauge steel and panel overlaps
- No pre-drilling of membrane and insulation required thanks to cutting-washer.
- Self-coring fastener without disruption of the insulating material achieved by the cutting washer
- Flexibility given to the installer due to dual drive, which provides both a Hex and Torx drive option
- Secured against unwinding given by cut-off thread-end and free-spin zone

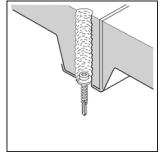

Fastener in A2 onto steel

Product code	PU	L	CLap	
SXP2-HT-SC19-5,5x25	500	25	0.8-20	1686837

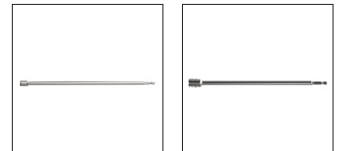

Accessories/Ancillaries

Product code	PU	Drive	Head Drive	Length	
Drive Bar HEX8-1/4"-300	1	1/4"	HEX8 Drive	300mm	1823798
T25W-175-HEX1/4"			T25 Drive	175mm	727979
T25HF-240-HEX1/4"				240mm	1223621